

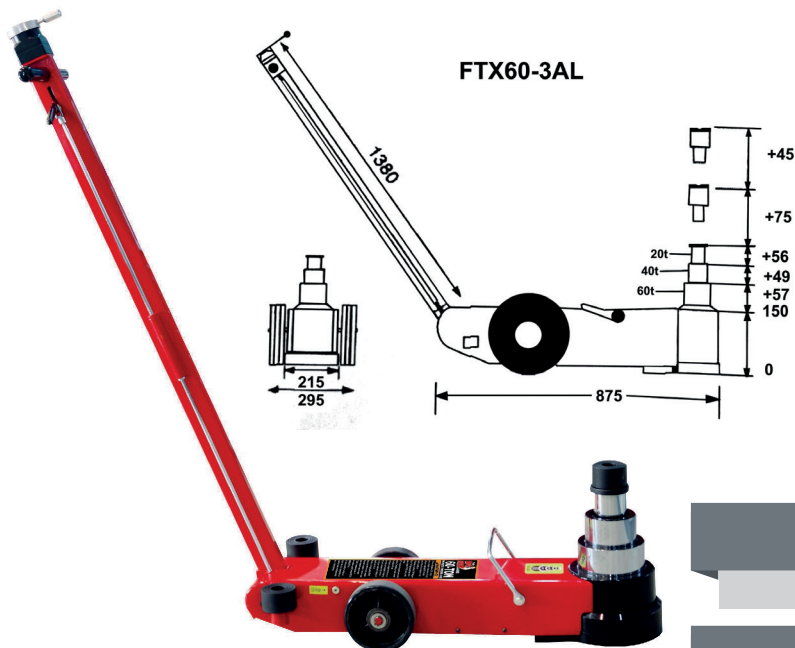

GATOS NEUMÁTICOS FTX60-3AL GATO NEUMATICO PROFESIONAL 20/40/60TON.



FORTEX®



8423640 152755

530000475

8423640152755

FTX60-3AL GATO NEUMATICO PROFESIONAL 20/40/60TON.

Capacidad / Capacity / Capacité	Ton	60 / 40 / 20
Altura Mínima / Min.Height / Hauteur Minimum	mm	150
Altura Máxima / Max.Height / Hauteur Maximum	mm	-
Presión aire / Aire pressure / Pression d'air	Bar	8 - 12
Recorrido / Lifting Height / Course	mm	60 ton : 57 / 40 ton : 49 / 20 ton : 56
Altura extensión / Extension height / Hauteur d'extension	mm	75 + 45
Rango elevación / Lifting range / Plage de levage	mm	60 ton : 57 / 40 ton : 49 / 20 ton : 56
Peso N-B / N-G Weight / Poids N-B	Kg.	2 / 2,2